

High level of protection against unsightly scratching!

Lexan* Margard* sheet has a unique, hard surface coating which provides a high level of protection against abrasion, so it's an excellent candidate for use in applications where frequent contact is likely.

High resistance to abrasion

To test abrasion the taber abrasion test (ASTM-1044 / ISO 3575) has been developed. A specific metal wheel - supported by a certain mass (normally 500 grams) - is rotated a number of cycles on the sheet sample.

Typically 100 cycles or 500 cycles are being used. After the test the % haze is being measured. The % haze is a direct indication of the loss of light transmission of the tested samples. The taber test is an excellent test to forecast on how a material will behave in a "high wear environment." The higher haze value the lower the resistance to wear



Material	% Haze (100 cycles)	% Haze (500 cycles)
Glass	2%	2%
Lexan Margard MRA3 sheet	3%	4%
Lexan Margard MR5E sheet	3%	9%
Lexan Margard FMR5 XT sheet	9%	25%
Lexan 9030/Exell D sheet	25%	35%
Acrylic	25%	35%
PVC	30%	36%

Taber abrasion test

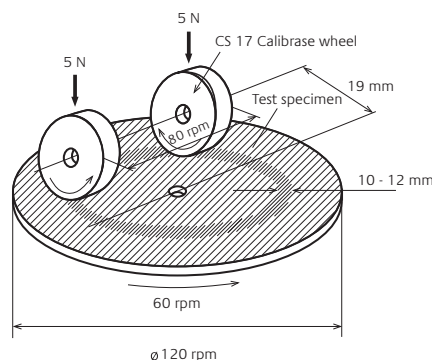
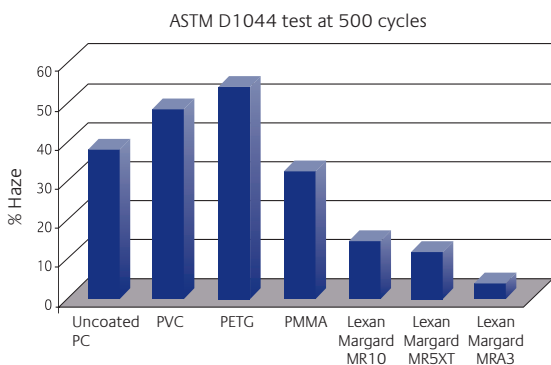

Lexan* Margard* sheet scratch resistance



Samples after 500 rotations

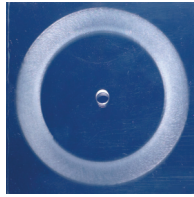

Lexan 9030 sheet

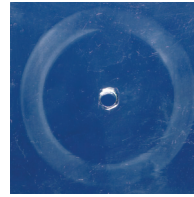

Glass

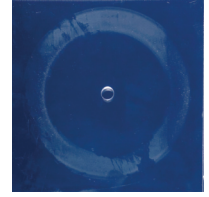

Lexan Margard MR5E sheet

Samples after 100 rotations

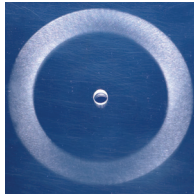

Lexan 9030 sheet

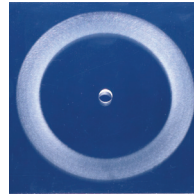

Acrylic

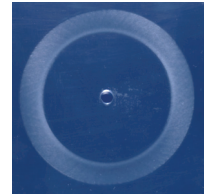

Lexan Margard FMR5XT sheet

Americas

SABIC Innovative Plastics
Specialty Film & Sheet
One Plastics Avenue
Pittsfield, MA 01201
USA
T 800 451 3147
T 413 448 5400
F 413 448 7506

Europe

SABIC Innovative Plastics
Specialty Film & Sheet
Plasticslaan 1
PO Box 117
4600 AC
Bergen op Zoom
The Netherlands
T +31 164 292911
F +31 164 292940

Pacific

SABIC Innovative Plastics
Specialty Film & Sheet
1266 Nanjing Road (W)
Unit 902-907, Plaza 66
200040 Shanghai
China
T +86 21 3222 4500
F +86 21 6289 8998

Email

sfs.info@sabic-ip.com

Lexan* Tough
Film and Sheet Virtually
Unbreakable

*Trademark of SABIC Innovative Plastics IP BV

THE MATERIALS, PRODUCTS AND SERVICES OF SABIC INNOVATIVE PLASTICS HOLDING BV, ITS SUBSIDIARIES AND AFFILIATES ("SELLER"), ARE SOLD SUBJECT TO SELLER'S STANDARD CONDITIONS OF SALE, WHICH CAN BE FOUND AT <http://www.sabic-ip.com> AND ARE AVAILABLE UPON REQUEST. ALTHOUGH ANY INFORMATION OR RECOMMENDATION CONTAINED HEREIN IS GIVEN IN GOOD FAITH, SELLER MAKES NO WARRANTY OR GUARANTEE, EXPRESS OR IMPLIED, (i) THAT THE RESULTS DESCRIBED HEREIN WILL BE OBTAINED UNDER END-USE CONDITIONS, OR (ii) AS TO THE EFFECTIVENESS OR SAFETY OF ANY DESIGN INCORPORATING SELLER'S PRODUCTS, SERVICES OR RECOMMENDATIONS. EXCEPT AS PROVIDED IN SELLER'S STANDARD CONDITIONS OF SALE, SELLER SHALL NOT BE RESPONSIBLE FOR ANY LOSS RESULTING FROM ANY USE OF ITS PRODUCTS OR SERVICES DESCRIBED HEREIN. Each user is responsible for making its own determination as to the suitability of Seller's products, services or recommendations for the user's particular use through appropriate end-use testing and analysis. Nothing in any document or oral statement shall be deemed to alter or waive any provision of Seller's Standard Conditions of Sale or this Disclaimer, unless it is specifically agreed to in a writing signed by Seller. No statement by Seller concerning a possible use of any product, service or design is intended, or should be construed, to grant any license under any patent or other intellectual property right of Seller or as a recommendation for the use of such product, service or design in a manner that infringes any patent or other intellectual property right.

SABIC Innovative Plastics is a trademark of SABIC Holding Europe BV

* Lexan and Margard are trademarks of SABIC Innovative Plastics IP BV

© Copyright 2008 SABIC Innovative Plastics IP BV. All rights reserved.

sabic-ip.com

SABIC-SFS-2746